

A PROCESS REFRACTOMETER FOR CONCENTRATION MEASUREMENT OF LIQUIDS

K-PATENTS

PROCESS INSTRUMENTS

 **techmation** bv



K-PATENTS PROCESS REFRACTOMETER PR-23-GP

TYPICAL APPLICATIONS

CHEMICALS

Acetic acid, Acrylate, Amine oxide, Amino acid, Ammonium fluoride, Ammonium hydroxide, Ammonium nitrate, Ammonium sulphate, Caustic soda, Cellulose derivatives, Citric acid, Copper chloride, Chromium trioxide (or Chromic acid), Ethylene glycol, Formaldehyde, Formic acid, Glycerol, Hydrogen peroxide, Iron chloride, Lactic acid, Lubricating oils, Nickel chloride, Nitric acid, Oleum, Polyamides, Polycarbonates, Polyethylene, Resins, Sodium bicarbonate, Sodium dichromate, Sodium gluconate, Sodium hydroxide, Styrenes, Sulphuric acid, Urea, etc.

PLASTICS AND FIBERS

Acetate, Acrylics, Adipic acid, Caprolactam, Cyclohexanol, Cyclohexanon, Dimethylterephthalate, Dimethylformamide, Fiberglass, Hexamethylene diamine, Nylon salt, Polyamides, Polyesters, Rayon, Spandex, Vinyls. Finishing, coating and dyeing mediums of textiles.

PULP AND PAPER INDUSTRY

Alum, Black liquor, CMC, Latex, Sizing chemicals and binders, Starch, PVA, Retention chemicals.

SALTS AND SODIUM COMPOUNDS

Brine, Glauber's salt, Sodium carbonate, Sodium chloride, Sodium sulfate, Sodium sulfite, etc.

SOAP AND DETERGENTS

Fatty acids, Fatty alcohols, Caustic potash, Caustic soda, Glycerol, Salt, Soda ash, Sodium bicarbonate

STARCH SWEETENERS

Fructose, high fructose corn syrup, sorbitol, dextrose, glucose, xylose, maltose, mannitol, lactitol, aspartame, flavors. Supersaturation and seeding point control of fructose and dextrose syrups, cooling crystallizer, precrystallizer, main crystallizer.

SUGAR

Sucrose, affination, extraction, press water, thick juice, thin juice, vacuum pan, molasses, mother liquor. Supersaturation and seeding point control, cooling crystallizer, precrystallizer, main crystallizer.



DIGITAL MEASUREMENT PRINCIPLE

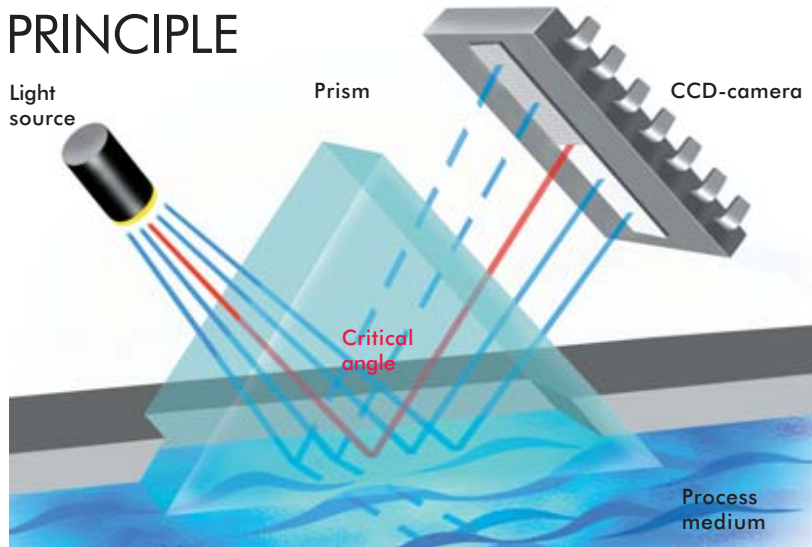

The light source sends light against the interface between a prism and the process solution, where the rays meet the surface at different angles.

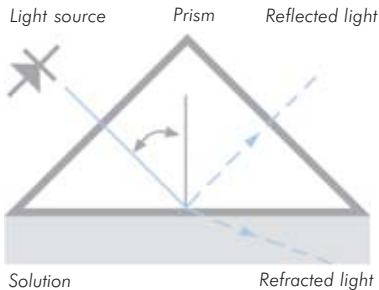

Depending on the angle, some rays are totally reflected. And, some rays are only partially reflected, most of the light is refracted into the process solution.

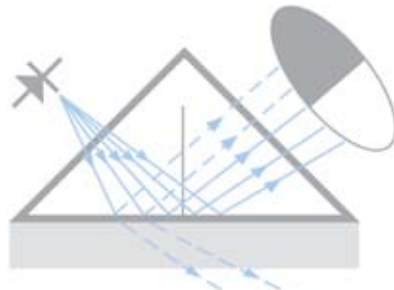

Thus an optical image with a dark sector and a light sector is created.

The angle corresponding to the shadow line is called the Critical Angle of Total Reflection. The Critical Angle is a function of the refractive index and therefore the concentration of the solution.

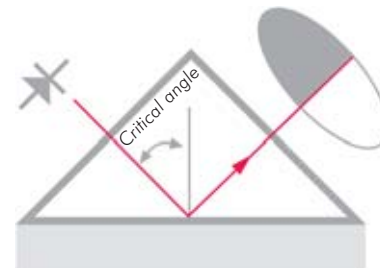

A digital CCD-camera detects the optical image and the shadow line. The camera transforms the optical image point-by-point to an electrical signal. The exact shadow line position is located and the refractive index n_D is determined.

A built-in temperature sensor measures the temperature T on the interface of the process liquid. The indicating transmitter converts the refractive index n_D and temperature T to concentration units.

The diagnostics program ensures that the measurement is reliable.

OPERATION

K-Patents Process Refractometer PR-23-GP provides truly accurate means for measuring liquid concentrations and Brix in various process applications. The K-Patents PR-23-GP determines the concentration of dissolved solids by making an optical measurement of a solution's refractive index.

The measurement accuracy is not influenced by particles, bubbles, sugar crystals, seeds, fibres, colour or temperature changes in the process medium. The K-Patents PR-23-GP does not require any recalibration or regular maintenance.

DATA LOGGING VIA ETHERNET

K-Patents PR-23-GP includes an Ethernet based communications solution which allows connection to computer networks (LAN) and to the Internet. Real-time measurement data and diagnostic information may be obtained through this interface, and this makes it also a valuable service tool for parameter changes and software updates.

Only a cross-over cable and data acquisition software are needed for collecting the data from a PR-23 refractometer. The communication is built on standard protocols (UDP/IP) and K-Patents offers ready-to-install software for data acquisition.

The K-Patents data acquisition software is expandable in case the user wants to modify the program. The program is written in Java and thus system independent. It can be tailored to almost any computing environment.

INSTALLATION

MEDIUM AND LARGE PIPES

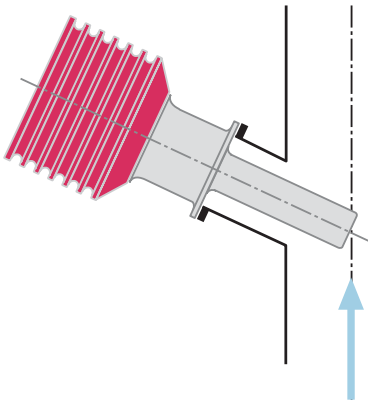

PIPES 2" OR SMALLER

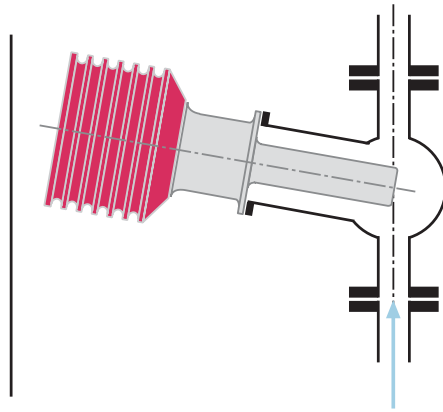

VESSELS

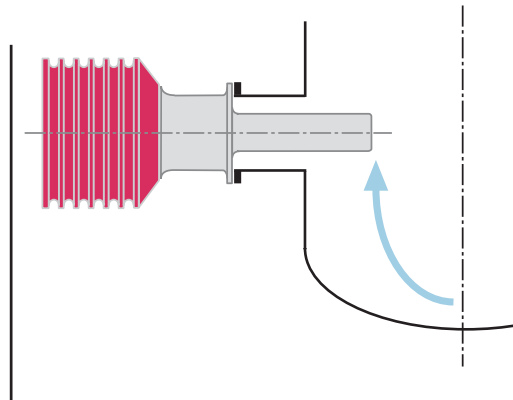
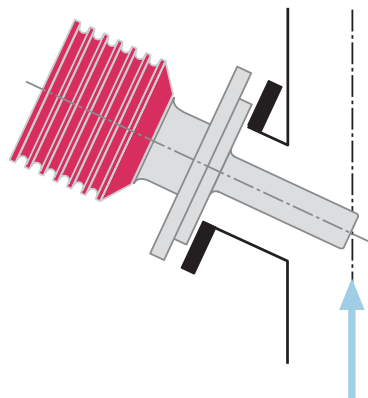

DUAL CONNECTIVITY

K-Patents Process Refractometer PR-23-GP sensor is factory calibrated to measure refractive index n_D and temperature T in standard units. Each sensor has identical calibration $n_D=1.32...1.53$ (corresponding to 0-100 Brix). One or two sensors can be connected to one Indicating transmitter.

Because the PR-23 sensors have identical calibration, and each sensor gives Refractive Index n_D and temperature as output, all sensors can be freely interchanged without any inconvenience of optical calibration or parameter changes.

The non-linear conversion from refractive index to concentration units and also temperature compensation are based on standard tables. They are programmed inside the transmitter independently of the sensor.

K-Patents' manufacturing process is ISO 9001 certified. K-Patents also supports the verification within the user's own quality system.

Each sensor is provided with a calibration certificate comparing a set of standard liquids to the actual sensor output. Therefore, the calibration and accuracy can be easily verified on-site with the certified refractive index liquids and K-Patents documented verification procedure.

DESIGN

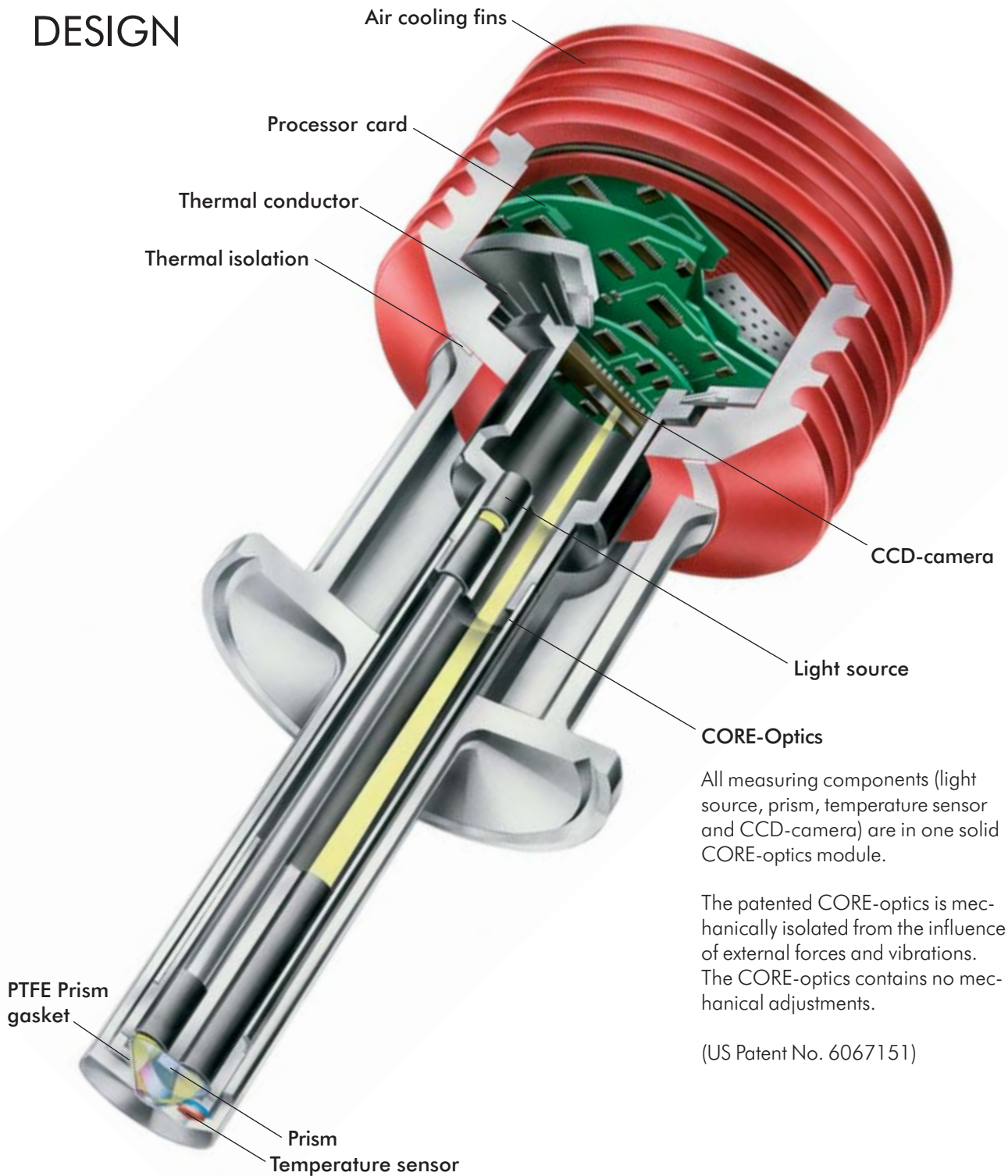

All measuring components (light source, prism, temperature sensor and CCD-camera) are in one solid CORE-optics module.

The patented CORE-optics is mechanically isolated from the influence of external forces and vibrations. The CORE-optics contains no mechanical adjustments.

(US Patent No. 6067151)

SPECIFICATIONS

Sensor PR-23-GP with Sandvik clamp

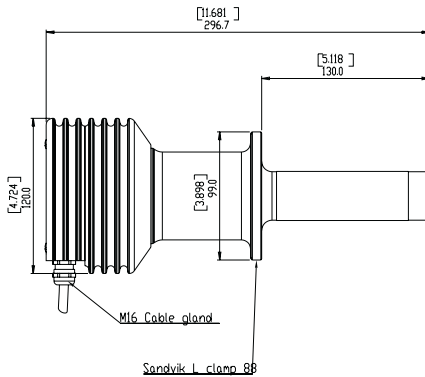

Sensor PR-23-GP with ANSI/DIN/JIS flange

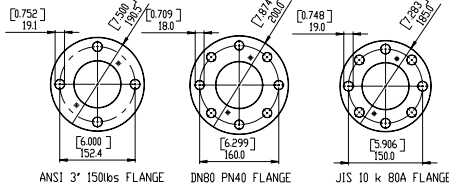
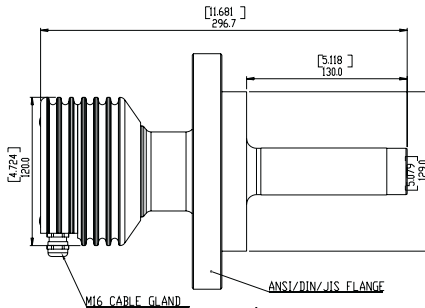

Indicating transmitter DTR

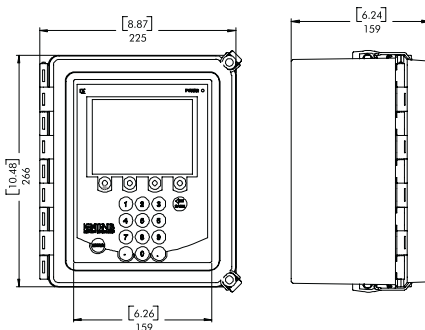

Refractive Index range:	Standard: Full range, $n_D = 1.3200...1.5300$ (corresponds to 0...100 % b.w.)
Accuracy:	Refractive index $n_D \pm 0.0002$ (corresponds typically to $\pm 0.1\%$ by weight) Repeatability and stability correspond to accuracy
Speed of response:	1 s undamped, damping time selectable up to 5 min
Calibration:	With Cargille standard R.I. liquids over full range of n_D 1.3200...1.5300
CORE-Optics:	No mechanical adjustments (US Patent No. US6067151)
Digital measurement:	3648 pixel CCD element
Light source:	Light emitting diode (LED), 589 nm wavelength, sodium D-line
Temperature sensor:	Built-in Pt-1000, linearization according to IEC 751
Temperature compensation:	Automatic, digital compensation
Instrument verification:	With standard R. I. liquids and K-Patents documented procedure according to ISO 9000 quality system
Ambient temperature:	Sensor: max. 45°C (113°F), min. -20°C (-4°F) Indicating transmitter: max. 50°C (122°F), min. 0°C (32°F)

SENSOR PR-23-GP:

Process connection:	Sandvik L clamp 88 mm/DIN-flange 2656, PN40 DN80/ANSI-flange 150 lbs, 3 inch/JIS-flange 10k 80A/Line sizes less than 2" via Pipe flowcell
Process pressure:	up to 25 bar (350 psi)
Process temperature:	-20°C...150°C (-4°F...302°F)
Process wetted parts, standard:	AISI 316L stainless steel, prism spinel, prism gaskets PTFE (teflon)
Sensor protection class:	IP67, Nema 4X
Sensor weight:	Sandvik clamp 3.8 kg (8.4 lbs), Flange DIN/ANSI/JIS 6.6 kg (14.1 lbs)

INDICATING TRANSMITTER DTR:

Display:	320x240 pixel graphical LCD with LED backlight
Keypad:	18 membrane keys
Current output:	Two independent current outputs, 4-20 mA, max. load 1000 Ohm, galvanic isolation 1500 VDC or AC (peak), hold function during prism wash
Ethernet connection:	10/100 Mbit/s, data acquisition over UDP/IP Protocol with K-Patents PR-11111 data logging software
Power:	AC input 100-240 VAC/50-60 Hz, optional 24 VDC, 30 VA
Alarms/Wash relays:	Two built-in signal relays, max. 250 V/3 A
Sensor connectivity:	One or two sensors can be connected to the DTR. Sensors independent of each other: own parameter sets and usable in different applications. Two current outputs configurable independently to indicate process concentration or temperature of either sensor.
Transmitter protection class:	Enclosure IP66, Nema 4X
Indicating transmitter weight:	4.5 kg (10 lbs)

INTERCONNECTING CABLE:	IEC 61158-2 compliant two-wire cable
Interconnecting cable length:	Standard 10 m (33 ft), max. 200 m (660 ft)

OPTIONS:	Stainless steel sensor housing, prism wash, cable fittings to the indicating transmitter: European cable glands M20x1.5 or US conduit hubs
-----------------	--

ORDERING INFORMATION:	- Sensor type and process connection - Desired scale - Properties of process solution - Process temperature range	- Process pipe size - Process flow rate - Supply voltage and frequency - Options and accessories
------------------------------	--	---

Techmation b.v.

P.O. box 195
NL - 4250 DD Werkendam

Phone +31.183.500.331 www.techmation.nl
Fax +31.183.500.342 sales@techmation.nl

We reserve right to technical alterations.