

AN OEM REFRACTOMETER
FOR IN-LINE BRIX
MEASUREMENT

K-PATENTS
PROCESS INSTRUMENTS

 **techmation** bv



K-PATENTS SANITARY OEM REFRACTOMETER PR-33-AC

TYPICAL APPLICATIONS

BEVERAGES

Extraction, evaporation, brewing, distilling, blending and filling. Alcohol, rum, molasses, liquors, cider. Beer, wort, cut beer, root beer. Juices, blended vegetable juice, blended fruit juices and nectars, still drinks, vegetable and juice concentrates, ice tea, ice coffee, instant coffee, instant tea. Soft drinks, energy and sport drinks, beverage base. Wines, grape must.

CEREALS

Sugar syrup.

CONFECTIONARY

Candies, caramel, flavors, syrup, topping, sugar coating.

CULTURES, ENZYMES, YEAST

DAIRY

Condensed milk, skimmed milk, milk powder, caseinate, yeast extract, yoghurt, ice cream, whey, lactose.

EGG

Egg white, egg yolk, whole egg, mixes with added sugar or salt, egg powder.

FLAVOURS AND INGREDIENTS

FRUIT AND VEGETABLE PROCESSING

Preserves, canned fruits, canned vegetables, vegetable extract, sauces, instant soups. Soy, soy milk. Tomato based products, tomato puree, ketchup.

PRODUCT AND CIP INTERFACES

Product to product interfaces, product to CIP interfaces.

QUALITY CONTROL AND TESTING

SUGAR DISSOLVING

Standardized sugar syrup.



K-PATENTS SANITARY OEM REFRACTOMETER PR-33-AC

SOLUTION FOR OEM

K-Patents has used its process refractometer expertise to develop a light, compact style refractometer model with rugged industrial durability and dependability. K-Patents Sanitary OEM Refractometer PR-33-AC is designed to meet the needs of original equipment manufacturers (OEMs) and integrators serving beverage, dairy and food processing industries.

The Sanitary OEM Refractometer has a measurement range of 0 to 100 Brix and provides a 4–20 mA output signal proportional to the temperature compensated Brix value for real-time process control.

The Sanitary OEM Refractometer sensor is installed in the main processing line and no by-pass arrangements are required. The sensor is angle mounted in the outer corner of the pipe bend directly or through a flow cell or a Sanitary clamp. This way the best flow conditions and self-cleaning effect can be achieved. The sensor can also be mounted with a Varivent® connection.

The Sanitary OEM Refractometer is Sanitary 3-A approved and EHEDG tested to meet the highest hygiene requirements of food production. It withstands the rigors of food processing such as process temperatures up to 130°C (265°F), CIP and SIP processes and cleaning and rinsing of facilities.

The Sanitary OEM Refractometer is factory calibrated to measure Brix and temperature in standard units. Each Sanitary OEM sensor has identical calibration. Because of this, the Sanitary OEM sensors can be freely interchanged without optical recalibration or parameter changes. The Sanitary OEM Refractometer does not require any recalibration or regular maintenance.

Wiring the Sanitary OEM Refractometer to a control loop is as simple as plugging a connector into the receptacle.

IN-LINE INSTALLATION

2.5 inch Sanitary clamp

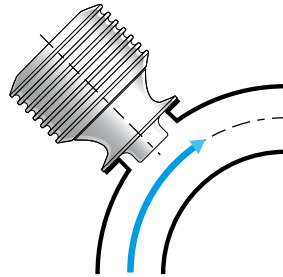

2.5 inch Sanitary clamp and flow cell

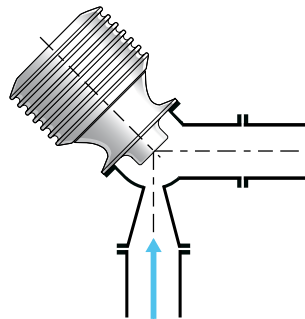

2.5 inch Sanitary clamp and flow cell

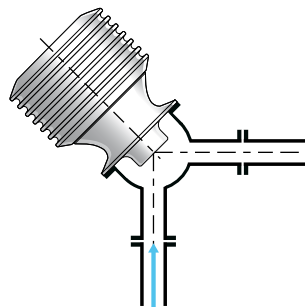

Varivent® connection

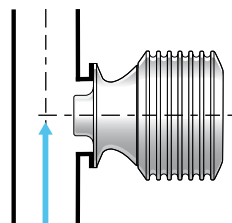

ACCURATE OPERATION

K-Patents Sanitary OEM Refractometer PR-33-AC provides truly accurate means for measuring Brix. The Sanitary OEM determines the concentration of dissolved solids by making an optical measurement of a solution's refractive index n_D . The measurement is automatically temperature compensated.

The measurement accuracy is $n_D \pm 0.0002$ and repeatability is $n_D \pm 0.0001$, which result in repeatability of ± 0.05 Brix. The same accuracy and repeatability are provided across the full measurement range of 0–100 Brix.

The output values of the sensor are transmitted through a 4–20 mA output and an Ethernet connection by using a UDP/IP protocol.

The measurement is not influenced by bubbles, particles, sugar crystals, seeds, fibres, color or temperature and pressure changes in the process medium.

K-Patents' manufacturing process is ISO 9001 certified. K-Patents also supports the verification within the user's own quality system. The calibration and accuracy of the Sanitary OEM Refractometer can be easily verified on-site with the certified refractive index liquids.

DIGITAL MEASUREMENT PRINCIPLE

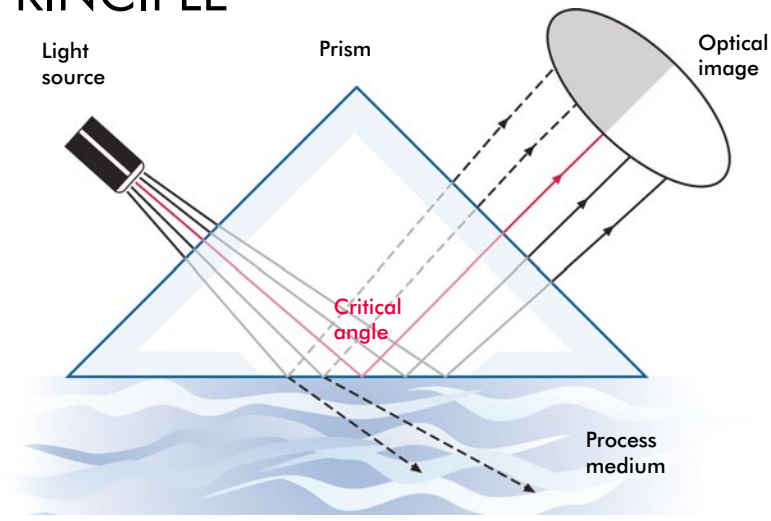

The light source sends light against the interface between a prism and the process solution, where the rays meet the surface at different angles.

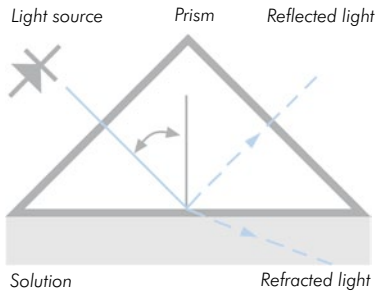

Depending on the angle, some rays undergo a total internal reflection. The rest of the light is refracted into the process solution.

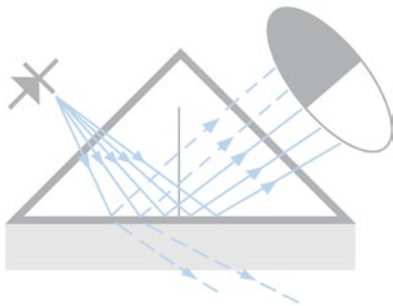

Thus an optical image with a dark sector and a light sector is created.

The angle corresponding to the shadow line is called the critical angle of total internal reflection. This angle is a function of the refractive index and therefore the concentration of the solution.

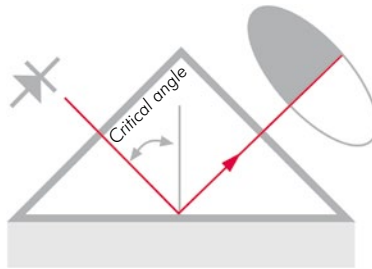

A CCD-camera detects the optical image. The image is transformed point-by-point into a digital signal. Digital signal processing is used to locate the exact shadow line position and to determine the refractive index n_D .

A built-in temperature sensor measures the temperature T on the interface of the process liquid. The sensor converts the refractive index n_D and temperature T to Brix units.

The diagnostics program ensures that the measurement is reliable.

DATA LOGGING VIA ETHERNET

K-Patents Sanitary OEM Refractometer PR-33-AC is the most advanced refractometer on the market since it includes an Ethernet based communications solution. This allows connection and data download to a computer. Real-time measurement data and diagnostic information may be obtained through this interface, and this makes it also a valuable service tool for parameter changes and software updates.

Any computer with a standard Ethernet connection can be configured to view and download data from the sensor by using a standard web browser.

DESIGN

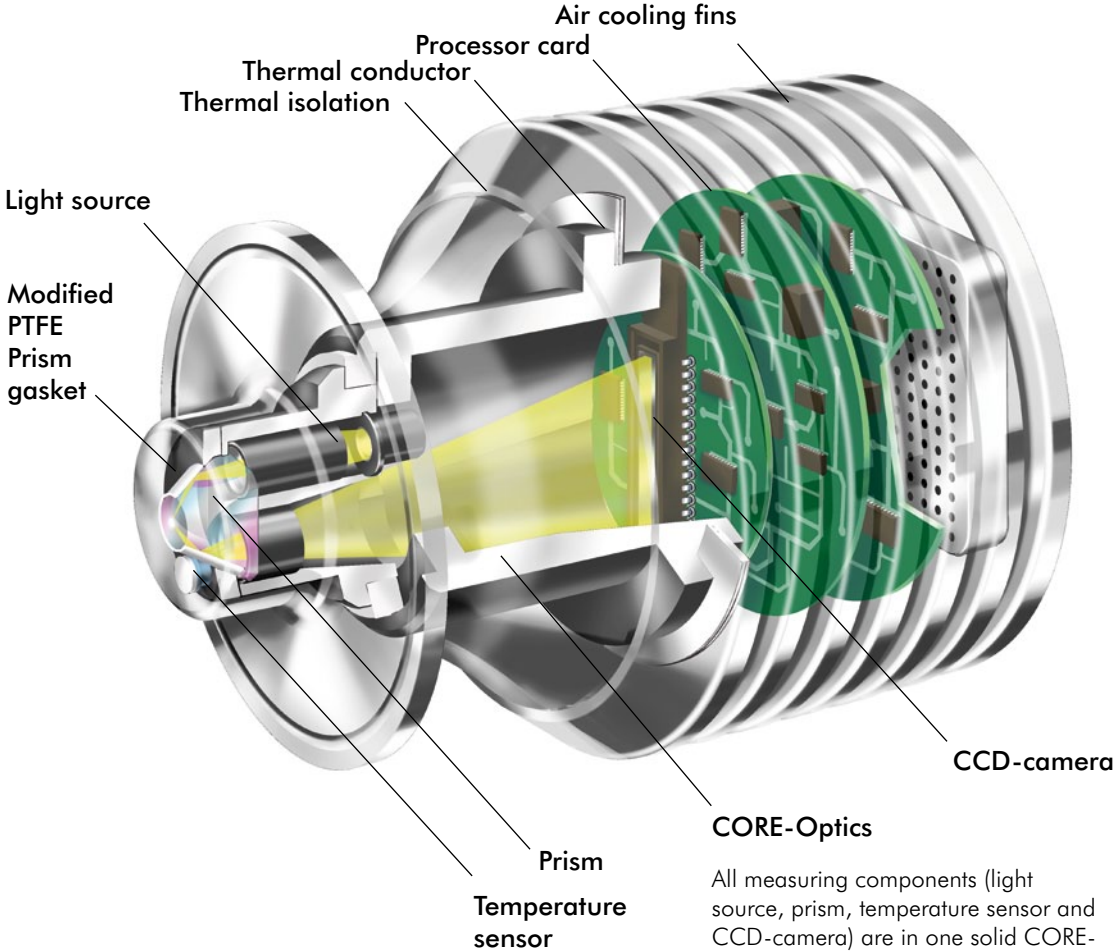

All measuring components (light source, prism, temperature sensor and CCD-camera) are in one solid CORE-optics module.

The patented CORE-optics is mechanically isolated from the influence of external forces and vibrations. The CORE-optics contains no mechanical adjustments.

(US Patent No. 6067151)

